

1. I. $a \otimes b = \begin{cases} a^3 + b^3, & a < b \\ 3ab - 15, & a \geq b \end{cases}$

II. $(-2) \otimes (3 \otimes 2) = ?$

I. eşitlikte \otimes işleminin görevi belirlenmiştir. Buna göre, II. eşitlikte soru işaretinin yerine aşağıdakilerden hangisi gelmelidir?

In equation I, the operation of \otimes is established. According to this operation, which of the following does the question mark stand for in equation II?

- A) -5 B) -1 C) 7 D) 13 E) 19

2.

+	a	b	c
a			12
b	15		
c		a	

a = ?

Yukarıdaki toplama tablosunda a, b ve c harfleri pozitif birer sayının yerine kullanılmıştır. Buna göre, a kaçtır?

In the addition table above, the letters a, b and c each stand for a positive number. Accordingly, what is the value of a?

- A) 7 B) 8 C) 9 D) 10 E) 11

3.

x	a	b	+	a	b	c
a		$c^2 + 1$	a			7
b	26		b			

a = ?

Yukarıdaki çarpma ve toplama tablolarında a, b ve c harfleri pozitif birer sayının yerine kullanılmıştır. Buna göre, a kaçtır?

In the multiplication and addition tables above, the letters a, b and c each stand for a positive number. Accordingly, what is the value of a?

- A) 1 B) 2 C) 3 D) 4 E) 5

4. – 5. sorularda verilen parçalar kullanılarak oluşturulan şekli bulunuz.

In questions 4 – 5, find the figure using given fragments.

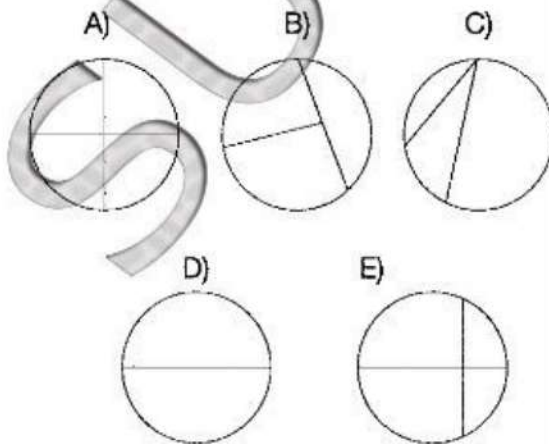
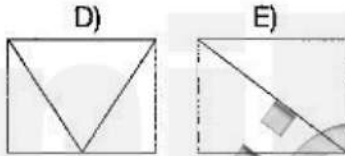
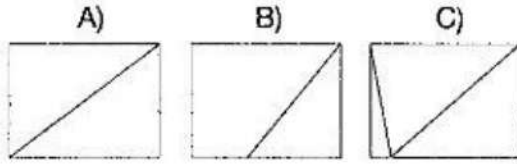
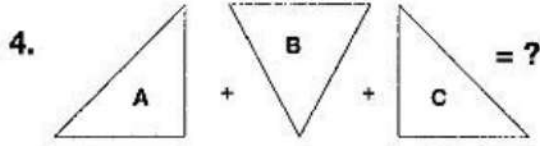

6. – 8. soruları örnekte verilen ilişkiye göre cevaplayınız.

In questions 6 – 8, find the correct answer in accordance with the relationship established in the example below.

ÖRNEK EXAMPLE

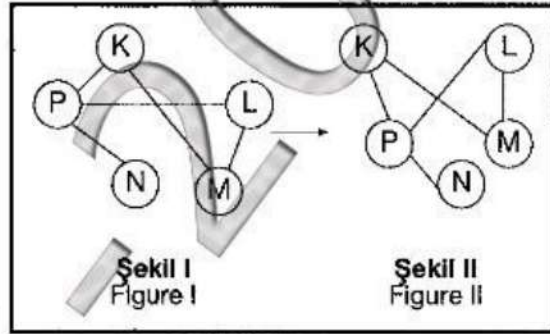

K, L, M, N ve P harfleri I. şekildeki gibi birbirine bağlanmıştır. I. şekildeki bağlantı sayıları ve birbirine bağlanan harfler değişmemek koşuluyla II. şekil elde edilmiştir.

Letters K, L, M, N and P are linked as in Figure I. Figure II has been constructed so as not to change which letters are linked to which, and the number of links made with each letter, in Figure I.

6.

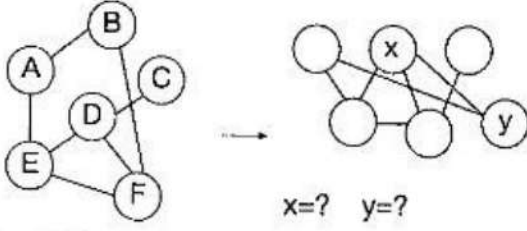

II. şekilde x ve y nin yerine gelmesi gereken harfleri bulunuz.

Find the letters that correspond to x and y in Figure II.

Find the letters that correspond to x and y in Figure II.

	<u>x</u>	<u>y</u>
A)	A	B
B)	F	B
C)	D	C
D)	E	F
E)	C	A

7.

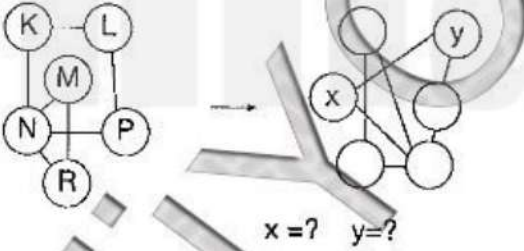

II. şekilde x ve y nin yerine gelmesi gereken harfleri bulunuz.

Find the letters that correspond to x and y in Figure II.

	<u>x</u>	<u>y</u>
A)	M	R
B)	P	L
C)	R	L
D)	P	M
E)	M	K

B

8.

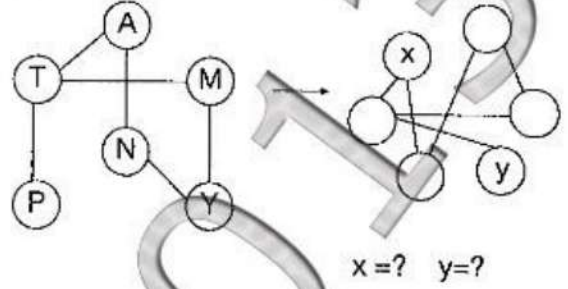

II. şekilde x ve y nin yerine gelmesi gereken harfleri bulunuz.

Find the letters that correspond to x and y in Figure II.

	<u>x</u>	<u>y</u>
A)	M	N
B)	T	A
C)	T	P
D)	M	P
E)	N	A

9. – 10. sorularda, soru işaretinin yerine getirilmesi gereken şekli bulunuz.

In questions 9 – 10, find the figure to replace the question mark.

11. – 14. sorularda, verilen şekil dizisinde soru işaretinin yerine getirilmesi gereken şekli bulunuz.

In questions 11 – 14, find the figure which the question mark stands for in the given figure sequence.

9.

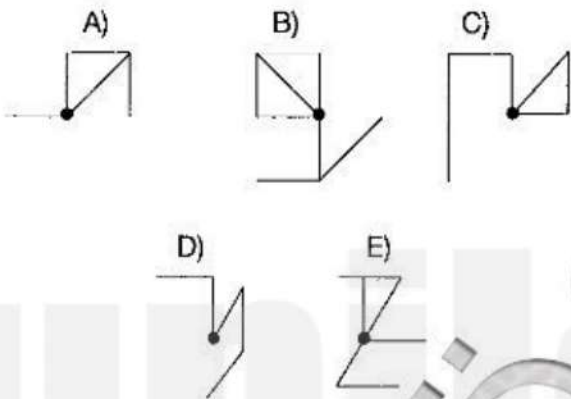
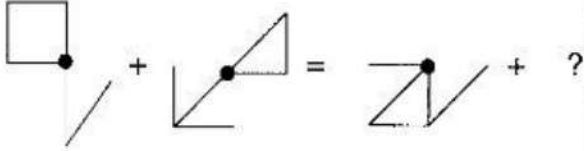

10.

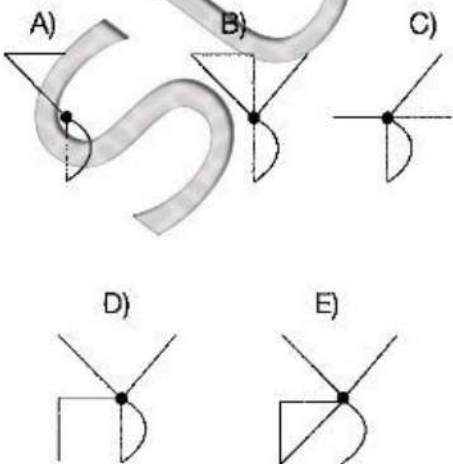

11.

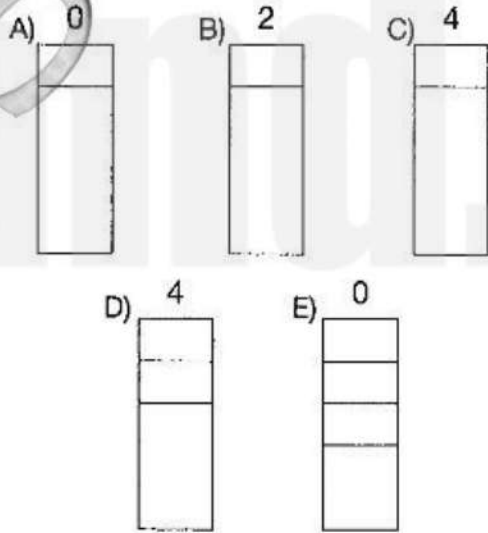
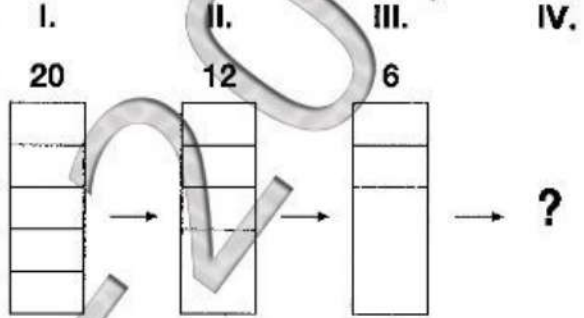

B

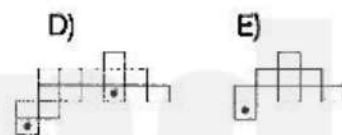
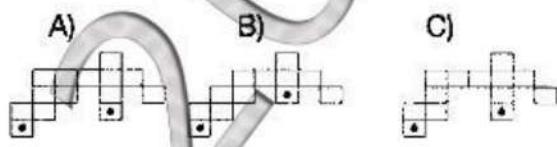
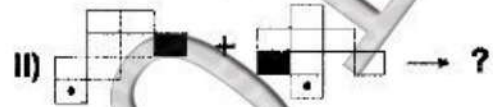
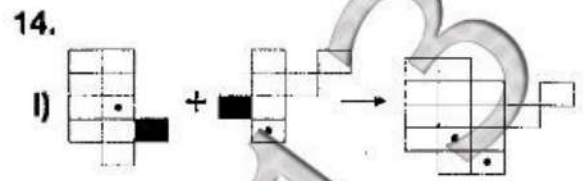
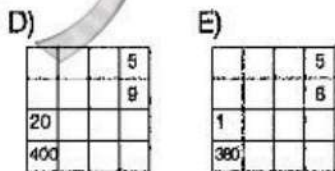
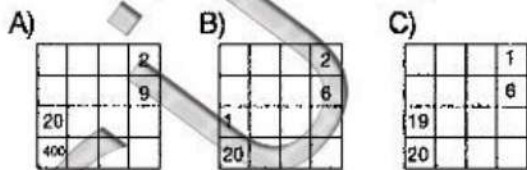
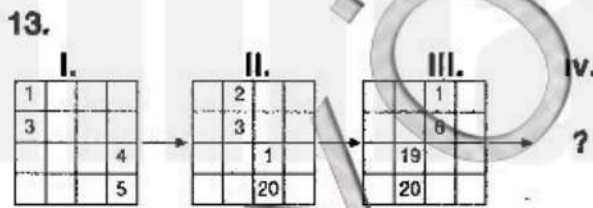
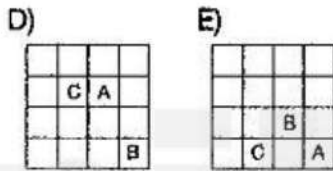
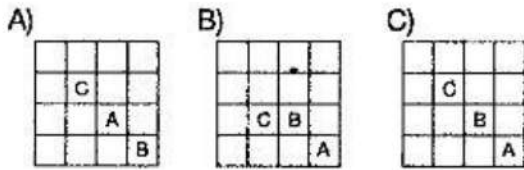
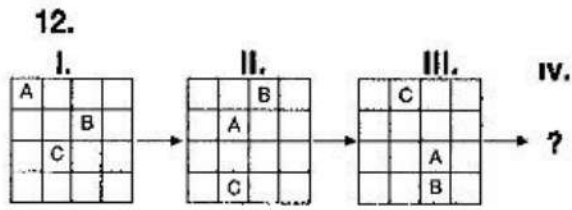

15.-16. sorulardaki (a_n) sayı dizisinde $a_1=2$, $a_2=3$, $a_3=2$ ve $n \geq 4$ için $a_n = a_{n-1} \cdot a_{n-2} + a_{n-3}$ olarak verilmiştir.

In questions 15.-16. (a_n) number sequence is given as $a_1=2$, $a_2=3$, $a_3=2$ and $n \geq 4$, $a_n = a_{n-1} \cdot a_{n-2} + a_{n-3}$

15. $a_4 + a_5 + a_6 = ?$

- A) 1 B) 2 C) 4
D) 6 E) 8

16. $a_{24} + a_{25} + a_{26} + a_{27} = ?$

- A) 0 B) 4 C) 8
D) 12 E) 16

17. ve 18. sorularda, I. gruptaki sözcüklerin harfleribirer rakamla gösterilerek II. gruptaki sayılarda edilmiştir. Soru işaretiyle belirtilen sözcüğün hangi sayıyla gösterildiğini bulunuz.

In questions 17 and 18, the numbers in group II stand for the words in group I, when each letter has been coded with a specific numeral. Find the number which corresponds to the word indicated by the question mark.

17. I.	II.
BACA	2434 4681 4147
BERE	2575 6595
AKAR	
AÇIK	
ÇETE	

AÇIK = ?

- A) 2434 B) 2575 C) 4147
D) 4681 E) 6595

18. I.	II.
KASA	1232 1289 7282
YAKA	1565 4212
KUTU	
MALA	
KALE	

MALA = ?

- A) 1232 B) 2787 C) 7282
D) 2787 E) 7828

19. ve 20. soruları aşağıdaki tabloya göre cevaplayınız.

Answer questions 19 and 20 in accordance with the table given below.

Δ	A	B	C	D	E
A	C	D	E	A	B
B	D	E	A	B	C
C	E	A	B	C	D
D	A	B	C	D	E
E	B	C	D	E	A

Tabloda Δ işleminin görevi belirlenmiştir.

The operation of Δ is established in the table

$$A \Delta D = A$$

$$B \Delta C = A$$

19. $(A \Delta B) \Delta (C \Delta D) = ?$

- A) A B) B C) C D) D E) E

20. $(x \Delta A) \Delta E = A$

$$x = ?$$

- A) A B) B C) C D) D E) E

21.

x	a	b
a	a+12	
b		6a+1

Yukarıdaki çarpma tablosunda a ve b harfleri pozitif birer sayının yerine kullanılmıştır. Buna göre, b kaçtır?

In the multiplication table above, the letters a and b each stand for a positive number. Accordingly, what is the value of b?

- A) 4 B) 5 C) 6 D) 7 E) 8

22.-24. sorular aşağıdaki tabloya göre cevaplayınız.

Answer questions 22.-24. in accordance with the table given below.

22.

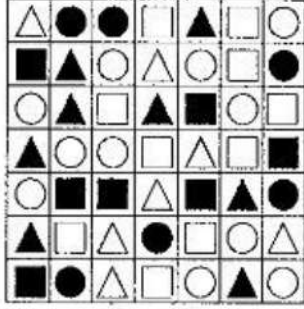

I.

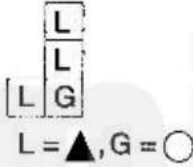

II.



I ve II, yukarıdaki tablonun farklı birer parçasıdır. Buna göre, II deki F ve K nin yerine aşağıdakilerden hangisi gelmelidir?

I and II are different parts of the figure above. Accordingly, which of the following combinations should replace F and K in II?

- | | F | K |
|----|-------------|----------------|
| A) | \square | \blacksquare |
| B) | \triangle | \blacksquare |
| C) | \bullet | \triangle |
| D) | \square | \bullet |
| E) | \triangle | \bullet |

23.

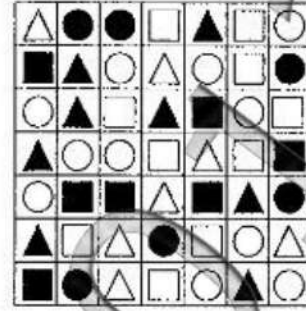

I.

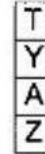

II.

T = \blacksquare , A = \triangle

Y = ?, Z = ?

I ve II, yukarıdaki tablonun farklı birer parçasıdır. Buna göre, II deki Y ve Z nin yerine aşağıdakilerden hangisi gelmelidir?

I and II are different parts of the figure above. Accordingly, which of the following combinations should replace Y and Z in II?

- | | Y | Z |
|----|------------------|-----------|
| A) | \square | \circ |
| B) | \blacktriangle | \square |
| C) | \circ | \bullet |
| D) | \bullet | \circ |
| E) | \square | \bullet |

24.

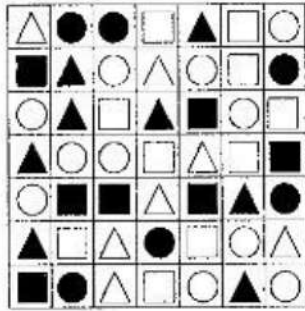

I.

II.



$$R = \blacktriangle, T = \blacksquare$$

$$E = ?, N = ?$$

I ve II, yukarıdaki tablonun farklı birer parçasıdır. Buna göre, II deki E ve N nin yerine aşağıdakilerden hangisi gelmelidir?

I and II are different parts of the figure above. Accordingly, which of the following combinations should replace E and N in II?

- E → N
- A)
- B)
- C)
- D)
- E)

B

25.

I. $a \triangle b = a.b$

II. $a * b = (a+2).b$

III. $(2 \triangle 3) * 5 = ?$

I. ve II. eşitliklerde \triangle ve $*$ işlemlerinin görevleri belirlenmiştir. Buna göre, III. eşitlikte soru işaretinin yerine aşağıdakilerden hangisi gelmelidir ?

In equations I and II, the operations of \triangle and $*$ are established. According to those operations, which of the following does the question mark stand for in equation III ?

- A) 35 B) 36 C) 37 D) 38 E) 40

26. ve 27. sorularda, I. gruptaki kümelerin şekilleri birer rakamla gösterilerek II. gruptaki sayılar elde edilmiştir. Soru işaretiyle belirtilen kümenin hangi sayıyla gösterildiğini bulunuz.

In questions 26 and 27, the numbers in group II stand for the sets of figures in group I, when each figure has been coded with a specific numeral. Find the number which corresponds to the set of the figures indicated by the question mark.

26.

I.

II.

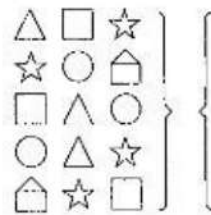

124 435 213

542 314

$$\square \triangle \bigcirc = ?$$

A) 124

B) 213

C) 435

D) 542

E) 314

27. I. II.
- | | | |
|---------|-----|----------------|
| * ■ □ ▲ | } { | 2345 6425 5063 |
| ◇ ▲ △ ■ | | 4310 1563 |
| □ ■ ◇ ○ | | |
| ▲ ○ △ ■ | | |
| △ □ * ▲ | | |

$$\blacksquare \triangle \square * = ?$$

- A) 3462 B) 3642 C) 3624
D) 3264 E) 3426

28. - 30. soruları aşağıdaki şekle göre cevaplayınız.

Answer questions 28 - 30 in accordance with the figure given below.

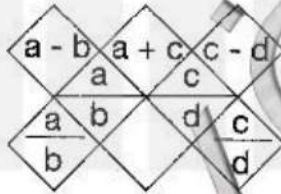

Yukarıdaki şekil a, b, c ve d harfleriyle gösterilen dört pozitif tam sayıyı içeren bazı işlemlere göre düzenlenmiştir. Harflerin gösterdiği sayılar her soruda farklı olabilir fakat, bunlarla yapılacak işlemler her soruda aynıdır.

The figure above has been organized according to various operations using four positive integers represented by the letters, a, b, c and d. The integers represented by the letters may change from question to question, but the operations to be done remain the same.

B

28.

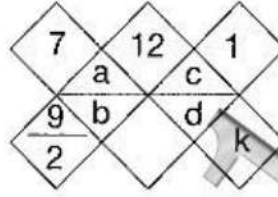

$$K = ?$$

Yukarıda verilen şekle göre, K kaçtır?

According to the figure above, what is the value of K?

- A) $\frac{1}{2}$ B) 1 C) $\frac{3}{2}$ D) 2 E) $\frac{5}{2}$

29.

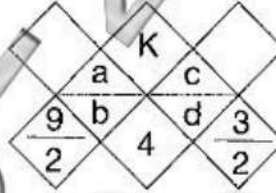

$$K = ?$$

Yukarıda verilen şekle göre, K kaçtır?

According to the figure above, what is the value of K?

- A) 12 B) 14 C) 16 D) 18 E) 20

30.

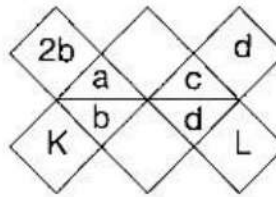

$$K + L = ?$$

Yukarıda verilen şekle göre, K+L kaçtır?

According to the figure above, what is the value of K+L?

- A) 2 B) 3 C) 4 D) 5 E) 6

31.

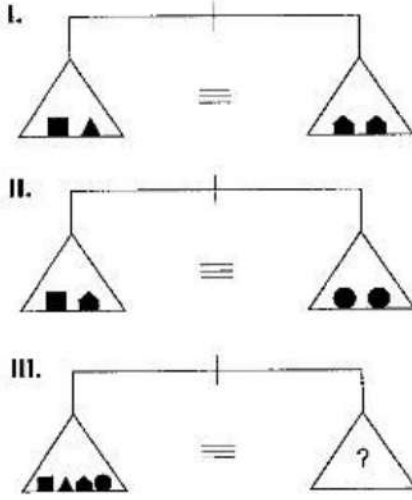

Yukarıdaki terazilerin üçü de dengede olduğuna göre, III. terazide soru işareti aşağıdakilerden hangisini göstermektedir?

All three scales above are in balance. Accordingly, which of the following does the question mark stand for in the third scale?

- A) ■▲▲● B) ●●●▲ C) ▲■
D) ●● E) ●▲▲

B

32.

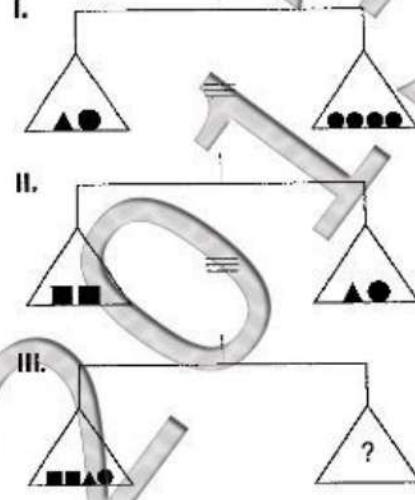

Yukarıdaki terazilerin üçü de dengede olduğuna göre, III. terazide soru işareti aşağıdakilerden hangisini göstermektedir?

All three scales above are in balance. Accordingly, which of the following does the question mark stand for in the third scale?

- A) ▲● B) ▲▲●● C) ●●▲
D) ●●● E) ■■

33.

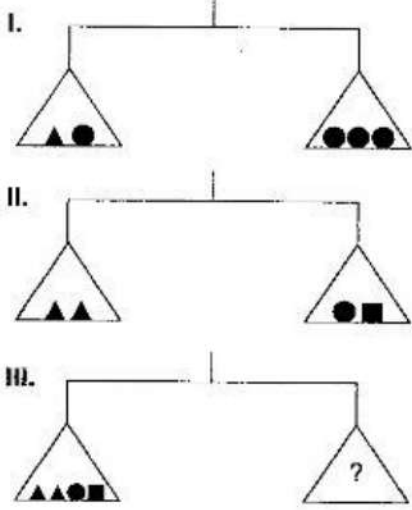

Yukarıdaki terazilerin üçü de dengede olduğuna göre, III. terazide soru işareti aşağıdakilerden hangisini göstermektedir?

All three scales above are in balance. Accordingly, which of the following does the question mark stand for in the third scale?

- A) ▲▲▲▲ B) ●●●● C) ●▲
D) ▲▲ E) ■▲

34.

Aşağıdakilerden hangisi üstü açık bir küpün açılımıdır.

(Which one is the expansion of the open cube)

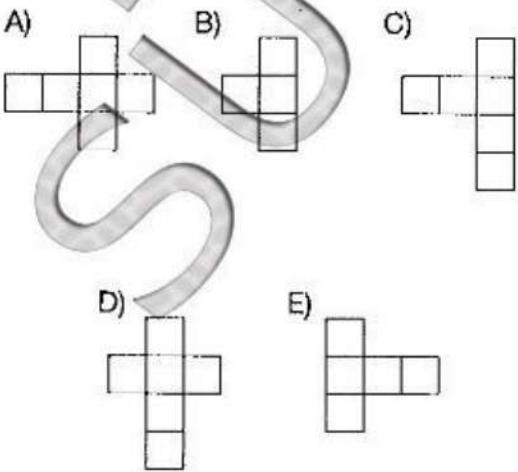

B

35.

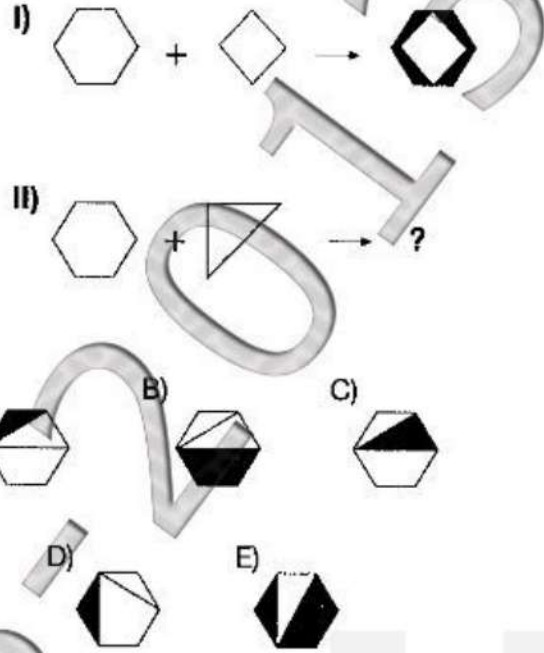

36.

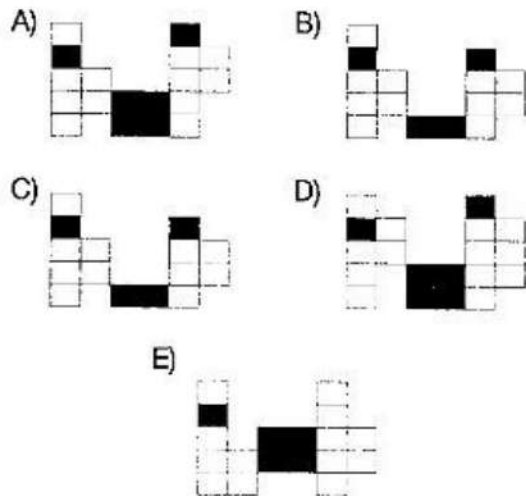
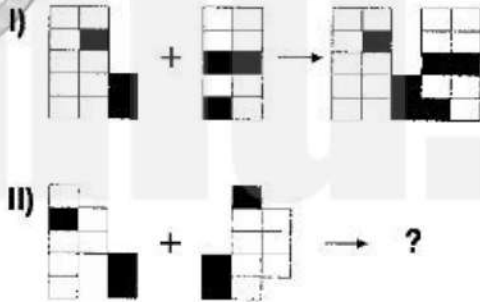

37. - 40. sorularda, verilen şekil matrisinde soru işaretinin yerine hangi şeklin getirilmesi gerektiğini bulunuz.gereken şekli bulunuz.

In questions 37. - 40, find the figure which the question mark stands for in the given figure matrix.

37.

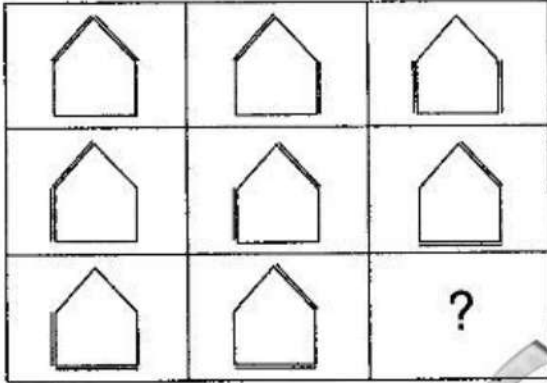

A)



B)



C)



D)



E)



B

38.

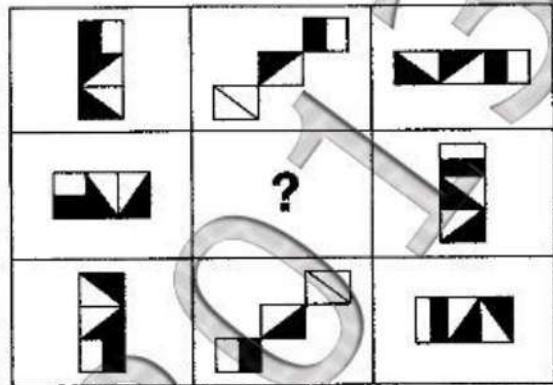

A)



B)



C)

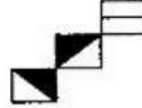

D)



E)



39.

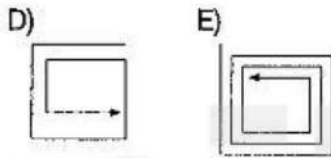
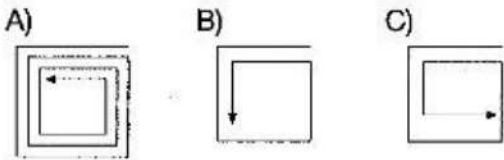
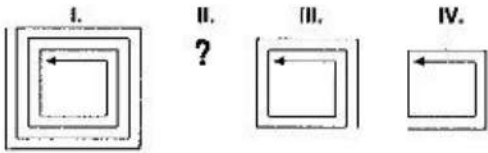

40.

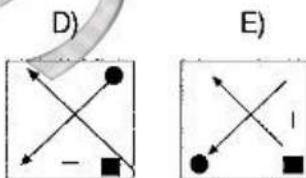
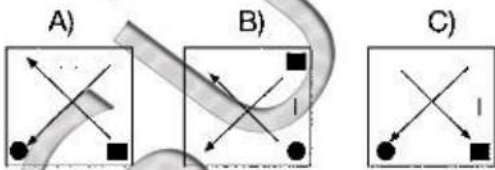
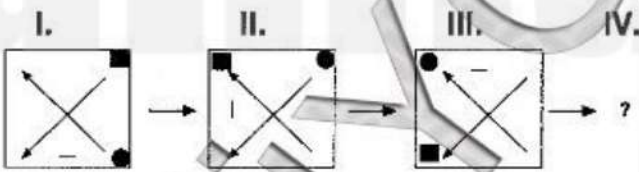

B

41.

$$\frac{\sqrt{3,61} + \sqrt{1,69}}{\sqrt{1,44} - \sqrt{0,64}} = ?$$

- A) 8 B) -8 C) 0,4 D) 0,8 E) 13

42.

$$\frac{a}{b} = \frac{2}{3}, a - b = \frac{5}{2}$$

$$a = ?$$

- A) 2 B) -1 C) 1 D) 5 E) -5 A) $\frac{5}{9}$ B) $-\frac{5}{9}$ C) $\frac{3}{7}$ D) $-\frac{3}{7}$ E) $\frac{1}{2}$

43.

$$\left(\frac{1}{4}\right)^{-4x} \cdot 16^{x-1} \cdot 64^{1-x} = 256$$

$$x = ?$$

- A) 1 B) -1 C) 2 D) -2 E) 0

44.

$$\log_4 2 + \log_9 3 - \log_4 27 = ?$$

- A) 2 B) -2 C) $\log_5 2$
D) $\log_2 3$ E) $-\log_3 2$

45.

$$\lim_{x \rightarrow 1} \frac{x^2 + 3x - 4}{x^2 + 7x - 8} = ?$$

- A) $\frac{5}{9}$ B) $-\frac{5}{9}$ C) $\frac{3}{7}$ D) $-\frac{3}{7}$ E) $\frac{1}{2}$

46.

$$f(x) = \ln\left(\frac{1 - \cos x}{\sin x}\right)$$

$$f'\left(\frac{\pi}{2}\right) = ?$$

- A) -1 B) 1 C) 0 D) 2 E) -2

47.

$$\frac{1}{4} - \left(\frac{1}{4} - \frac{1}{2} \right) - \left(\frac{1}{3} - \frac{1}{6} \right) - \frac{1}{6} = ?$$

- A) $\frac{1}{3}$ B) $\frac{1}{2}$ C) $\frac{1}{6}$ D) $-\frac{1}{6}$ E) $\frac{1}{4}$

48.

$$\left. \begin{array}{l} x - 2y = -1 \\ 2x + y = 3 \end{array} \right\} \Rightarrow \frac{2x^2 - 3xy - 4y^2}{\frac{x}{3} + \frac{y}{2}} = ?$$

- A) 12 B) -12 C) 6 D) -6 E) 1

49.

$$\frac{\cos 105^\circ}{\sin 15^\circ} = ?$$

- A) $-\frac{\sqrt{3}}{2}$ B) $\frac{\sqrt{3}}{2}$ C) $\sin 15^\circ$ D) 1 E) -1

50.

$$f(x) = \log_5 e^{5x}$$

$$f'(x) = ?$$

- A) $5/\ln 5$ B) $-5x$ C) $\ln 5$ D) $-\ln 5$ E) $5x$

51.

$$\int_4^5 \frac{dx}{x^2 - 5x + 6} = ?$$

- A) $-\ln\left(\frac{4}{3}\right)$ B) $\ln\left(\frac{5}{4}\right)$ C) $\ln\left(\frac{4}{5}\right)$
D) $\ln\left(\frac{4}{3}\right)$ E) $\ln\left(\frac{3}{4}\right)$

52.

$$\lim_{x \rightarrow 0} \frac{x + 2x \cos x}{3 \sin x \cos x} = ?$$

- A) -2 B) -1 C) 0 D) 1 E) 2

53.

$$y = (x^2 + 1)^{\sin x}$$

$$y'(0) = ?$$

- A) -2 B) -1 C) 0 D) 1 E) 2

54.

$$f(x) = 2x^2 + 1, g(x) = x - 2,$$

$$(f \circ g^{-1})(2) = ?$$

- A) 13 B) 15 C) 17 D) 19 E) 33

B

55.

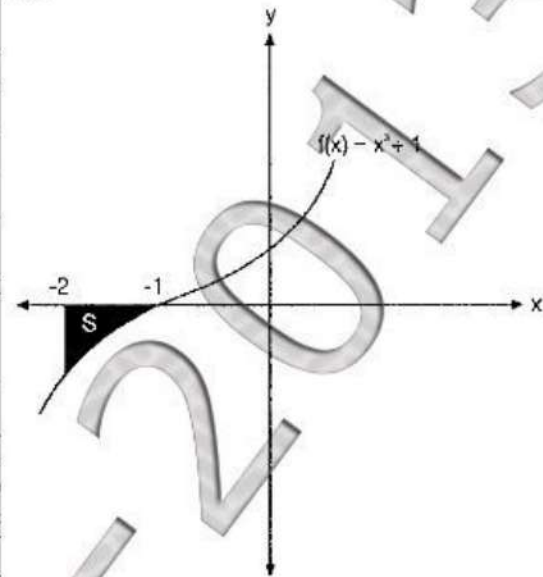

$$S = ? \text{ br}^2 \text{ (Unit Square)}$$

- A) 15/4 B) 11/4 C) 9/4 D) 2 E) 1

56.

$$\lim_{x \rightarrow \infty} \frac{\int_0^x \cos(t^2) dt}{x} = ?$$

- A) -2 B) -1 C) 0 D) 1 E) 2

57.

$$\sqrt{3} \cdot \sin \frac{\pi}{6} \cdot \cos \frac{\pi}{6} = ?$$

- A)1 B) $\sqrt{3}/2$ C)1/2 D)3/4 E)1/4

58.

$$\left[\left(2 - \frac{1}{3} \right) : \left(\frac{0,04}{0,4} \right) \right] - \frac{2}{3}$$

- A)-4 B)4 C)2 D)16 E)-16

59.

$$\sqrt[3]{a+1} - \sqrt[3]{16a+16} + 2\sqrt[3]{8|a+8|} = 10$$

a=?

- A)1 B)-8 C)8 D)-15 E)15

B

60.

$$\lim_{x \rightarrow 0} \frac{x - x \sin x \cos x}{\sin x \cos x} = ?$$

- A)-2 B)2 C)0 D)1 E)-1

61.

$$\log_5 2 = x$$

$$\log_{\sqrt{125}} \left(\frac{1}{64} \right) = ?$$

- A)x B)-x C)-2x
D)4x E)-4x

62.

$$\int_{-1}^1 \frac{d}{dx} (x^2 + x) dx = ?$$

- A)-4 B)-2 C)0 D)2 E)4

63.

$$f(x) = |\cos x|$$

$$f'\left(\frac{3\pi}{4}\right) = ?$$

- A) $-\sqrt{2}/2$ B) $-1/2$ C) 0 D) $1/2$ E) $\sqrt{2}/2$

64.

$$\lim_{x \rightarrow \infty} \frac{e^x \cdot (1+x)}{x^2} = ?$$

- A) $-\infty$ B) 0 C) $1/2$ D) 1 E) ∞

65.

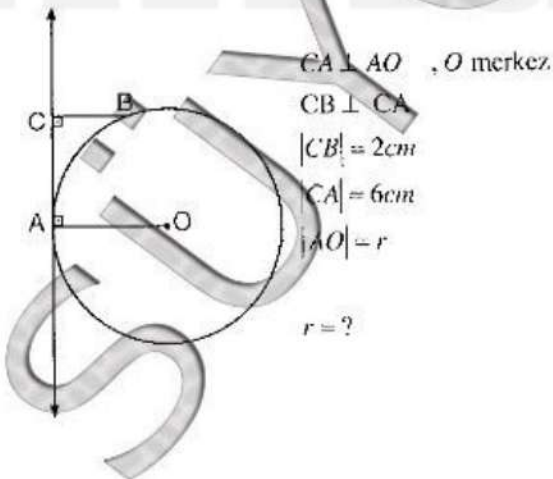

- A) 6 B) 7 C) 8 D) 9 E) 10

66.

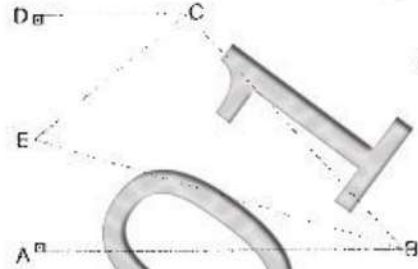

$$A(CEB) = 42 \text{ cm}^2$$

$$|DC| \parallel |AB|$$

$$|AD| \perp |AB|$$

$$|AD| \perp |DC|$$

$$|DC| = x \text{ cm}$$

$$|ED| = 4 \text{ cm}, |AB| = 12 \text{ cm}, |AE| = 6 \text{ cm}$$

$$x = ?$$

- A) 5 B) 6 C) 7 D) 8 E) 9

67.

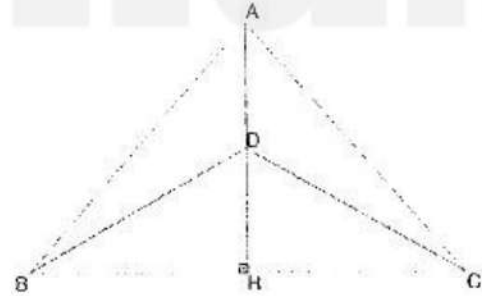

$$|AH| \perp |BC|$$

$$|BC| = 14 \text{ cm}$$

$$|AD| = 5 \text{ cm}$$

$$A(ABD) + A(ADC) = ? \text{ cm}^2$$

- A) 35 B) 40 C) 42 D) 45 E) 54

68.

$$\frac{\sin 7^\circ \cdot \cos 7^\circ}{\sin 83^\circ \cdot \cos 97^\circ} = ?$$

- A)0 B)1 C)-1 D)2 E)-2

69.

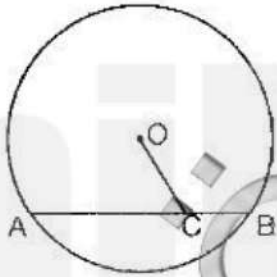

O merkez

$$|OC| = 9 \text{ cm}$$

$$|AC| = 9 \text{ cm}$$

$$|BC| = 7 \text{ cm}$$

O merkezli çemberin yarıçapı kaçtır?

- A)8 B)10 C)12 D)14 E)16

B

70.

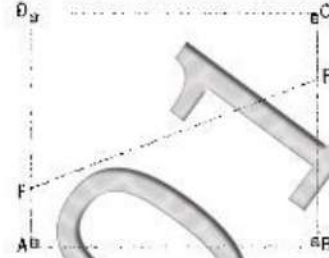

$$|CB| \perp |AB| \quad |CE| = 4 \text{ cm}$$

$$|AB| \parallel |DC|, |AF| = 3 \text{ cm}$$

$$|AD| \parallel |BC| \quad |EF| = 17 \text{ cm}$$

$$|AB| = |BC| = |CD| = |AD|$$

$$A(ABCD) = ? \text{ cm}^2$$

- A)225 B)169 C)144 D)100 E)81

71.

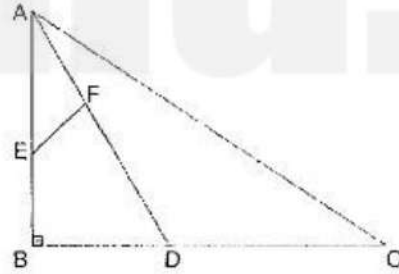

$$|AB| \perp |BC|$$

$$|AE| = |EB|$$

$$|BD| = |DC|$$

$$|AD| = 3|AF|$$

$$|AC| = 30$$

$$|EF| = ?$$

- A)5 B)6 C)7 D)8 E)9